

OpAmp Buffer Kit Building Manual







Effect Pedal Kits: OpAmp Buffer

OpAmp buffers are great to place at the beginning of your chain, or before any “tone-sucking” effect pedal. Our OpAmp buffer has a reduced board allowing it to be used as a mod for your effect pedals. Thanks to its high input impedance, it avoids sound degradation by preventing any loading to your guitar pickups.

Build your OpAmp buffer now and forget about tone loss!

BOM (1/2)

Resistors (8)				Capacitors (4)		
2	R1, R2	2.2M		1	C1	100n
3	R3, R4, R7	100k		1	C2	100u (electrolytic)
1	R5	100		2	C3, C4	10u (electrolytic)
1	R6	1k				
1	R8	10k				

BOM (2/2)

Diodes, Transistors and ICs			Generic Parts and Potentiometers		
1	U1	TL071	1	Battery clip	
			1	DC Jack	
			1	RLED	1k LED resistor
			1	LED Bezel	
			1	3PDT	
			2	IN, OUT	6.35mm Jacks

Component Placement

Note: if you want to use the buffer directly (i.e. soldered to your guitar output...) you can connect input, output and power jacks directly to "I", "O", and "+" in the board. All the grounds should be connected together and to the "G" pin in the board.

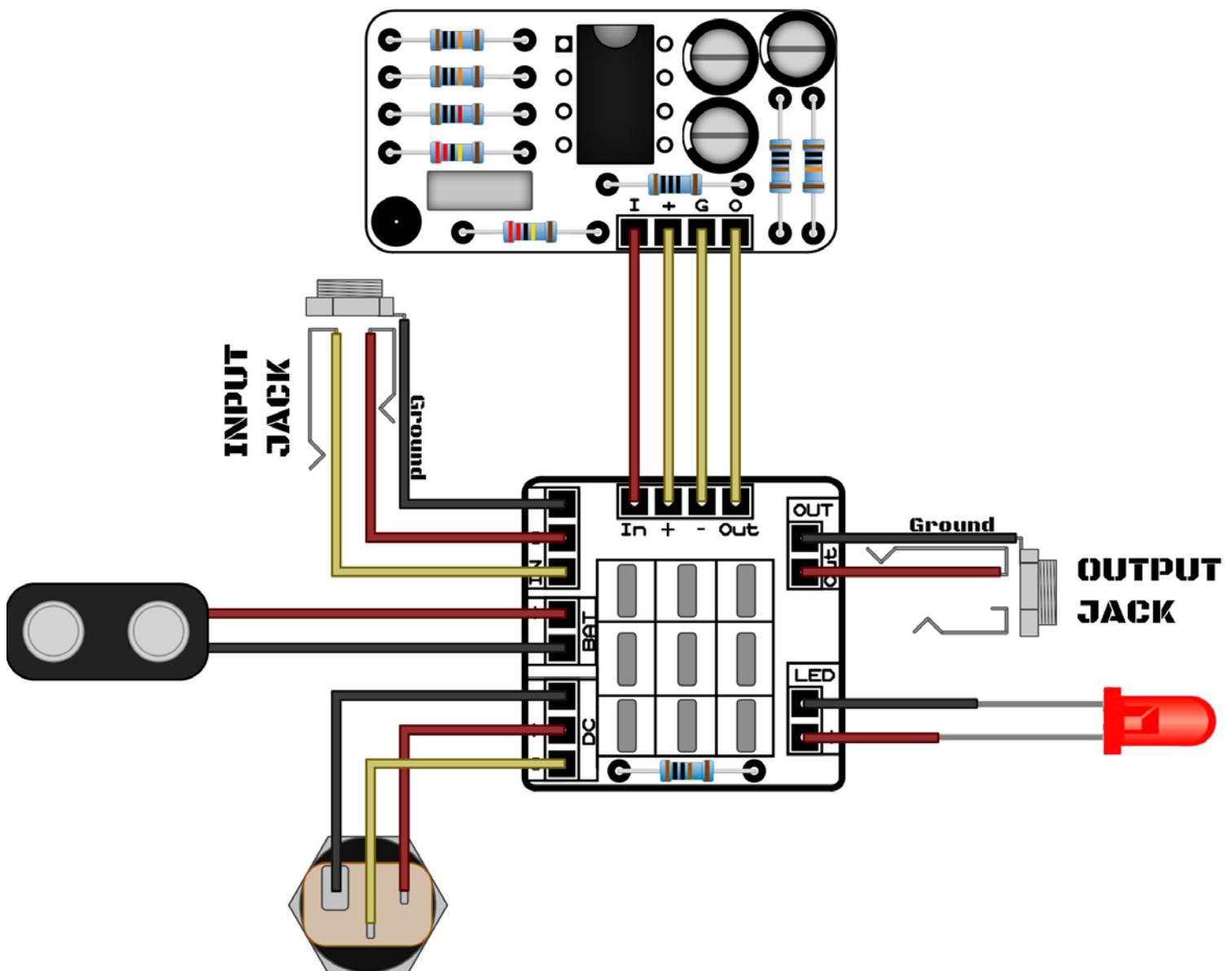

Board Layouts

3PDT PCB

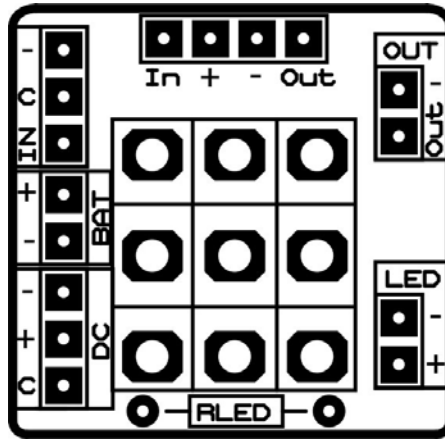

Effect PCB

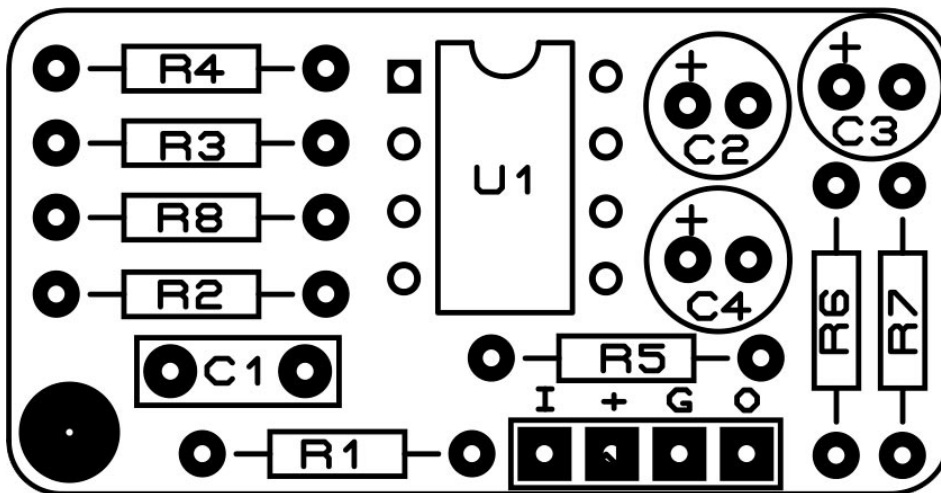

Building Tips

- 1- Pay attention to the **orientation of the 3PDT!** In the following picture you can see how the 3PDT pins should be positioned (inserting the pins in the holes can be a bit tight to avoid movement while soldering):

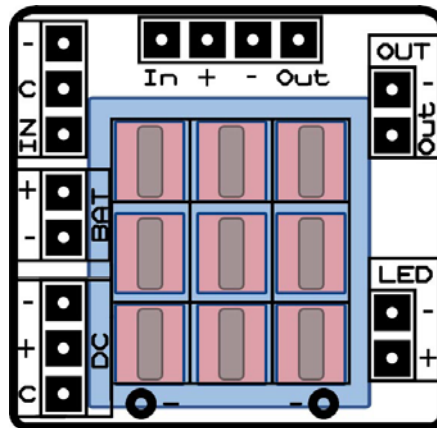

- 2- For a proper soldering you just have to apply the **right amount of solder wire**. A right solder joint should have a concave shape around the joint and look like this:



- 3- Don't apply too much heat! When soldering, the time you hold the solder iron against the joint should be **as short as possible** to avoid damaging any part (a few seconds should be enough). If you can't get a solder joint right, **let it cool** a bit before trying again.
- 4- If having troubles with the building, checking the schematic in the last page will help you find **where the audio signal stops**. When you find the spot, check out that **everything around that joint is ok** (components placed at their right place, solder joints...).

Building Tips

5- Pay attention to the **parts that have a polarity** and make sure they are connected as in the component placement picture:

- **ICs** (they have a small dot or indication that must fit the indication in the board)

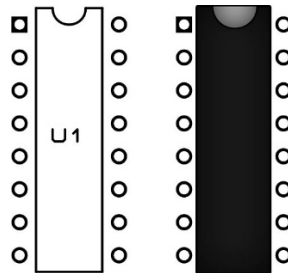

- **Electrolytic capacitors** (longer pin is connected to the “+” hole):



- **Diodes** (check for the mark and make it fit with the one in the PCB):

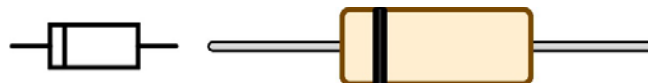

- **Leds** (longer pin is connected to the “+” hole)



- **Transistors** (inserted to fit the drawing in the PCB)



Building Tips

- 6- With the kit we include plastic PCB supports with an adhesive bottom. You can use them to anchor the PCB to your enclosure for a better stability. Just insert the PCB support tip into the 3.5mm holes and remove the adhesive protective film.

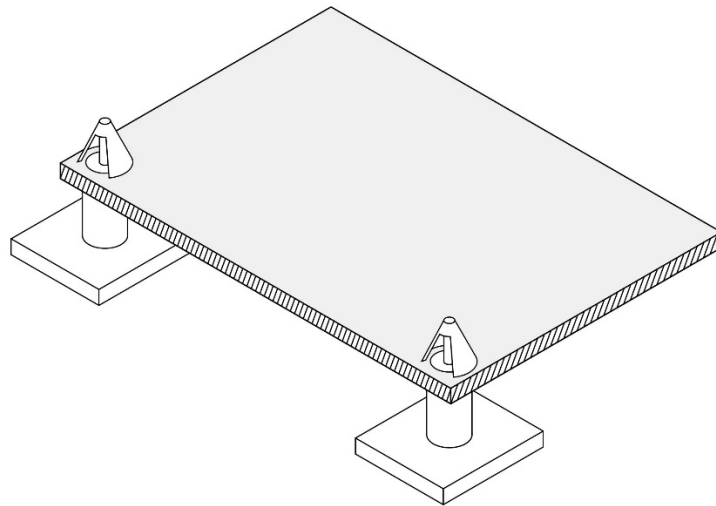

To avoid any issue always check the latest building manual. Use the pictures only as a reference! Colors/shapes of wires, PCB or parts can change slightly, this doesn't affect their functionality in any way.

Always double check part polarity, resistor and capacitor values, potentiometer placement, IC orientation... before soldering.

Schematic

